

MISTRAL Film

Overview

Pellenc ST offers a full sorting solution for plastic films at both the MRF and Recycling stages. Films can be separated at the MRF level from other plastic containers, including rigid PE containers. Plastic films can also be purified from contaminants at the recycling level, removing contaminants such as PP+PVC, Fibers, Metal, PS, HDPE (rigid), and nylon ropes. The MISTRAL FILM machine can easily make distinctions between films made of PE, PP, and PVC thanks to the specially and uniquely designed MISTRAL spectrometer and focus lighting system. The patented designed spectrometer allows Pellenc ST to achieve performances in the plastic film market that are unmatched by the rest. The MISTRAL FILM machine also uses the Pellenc ST Turbosorter which stabilizes light weight objects at high speeds for accurate sorting.

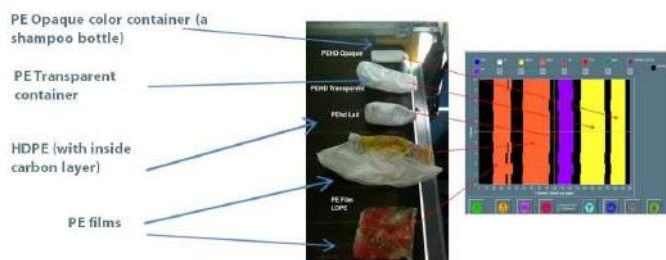

The MISTRAL NIR spectrometer can differentiate between all the materials within the PE family.

The MISTRAL Film can also remove the following contaminants:

- Fibers (paper, cardboard, textile)
- Metal (aluminum film, bottle springs, metal inserts, wires, caps)
- PS
- HDPE (rigid containers)
- Nylon ropes

Features

- Tailored made spectrometer using all information in the NIR range and Focused Light System
- Pellenc ST TURBOSORTER air stabilization system
- Special ejection box designed to handle light films using aeraulic treatment
- Compressed air regulator
- Light object blower
- Filter blower
- External AC power supply
- Jam blower

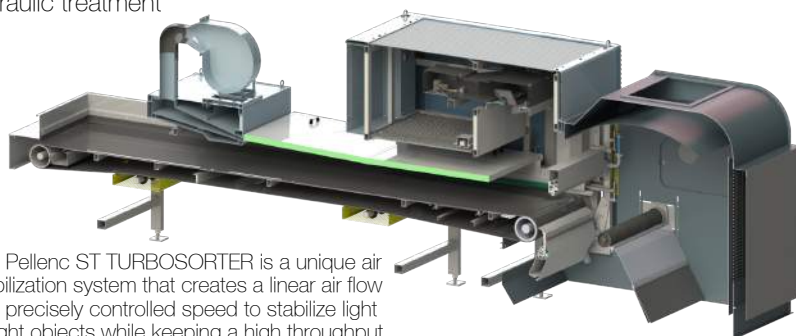

The Pellenc ST TURBOSORTER is a unique air stabilization system that creates a linear air flow at a precisely controlled speed to stabilize light weight objects while keeping a high throughput and accurate sorting with these materials.

Specifications

- Width of machines: 1200-2800mm
- Throughput: up to 2.5 tons/Hour
- Material size: 50-400mm (optimal)
- Film thickness: down to 10-15µm
- Ejecting PE film at MRF stage: up to 90% pure
- Ejecting contaminants at Recycling stage: up to 91% efficiency (close to 95% pure PE Film fraction)

Applications:

- | | |
|----------------------|------|
| Sorting Facilities | MRF |
| Recycling Facilities | Film |

