

XPERT



One machine for multiple sorting applications

- The new XPERT offers a unique combination of **dual-energy X-ray** measurement (density) along with **machine learning** (shape and thickness). This allows new sorting capabilities and **high performance**.
- The new XPERT includes **new X-ray generator up to 1000 Watts**, and a **new detector**, giving flexibility in a wide range of applications.
- **Top Speed Ready**, allowing a conveyor speed **from 2m/s up to 4,5m/s** depending on application, offers much more capacity with no compromise on performance.
- With the new software, the Xpert is able to target **multiple materials and densities** in a **single sorting step**.



Full Package : a complete system

- Certified radiologic system
- Designed for simple integration
- Easy and secure machine access

Built with the operator in mind

- User friendly software
- Low replacement rate of wearing parts
- Economical vortex cooling system (no air conditioning)

Service PACK

4 years extended warranty

- An all-in-one solution
- 24/7 services
- Controlled maintenance costs



Technologies

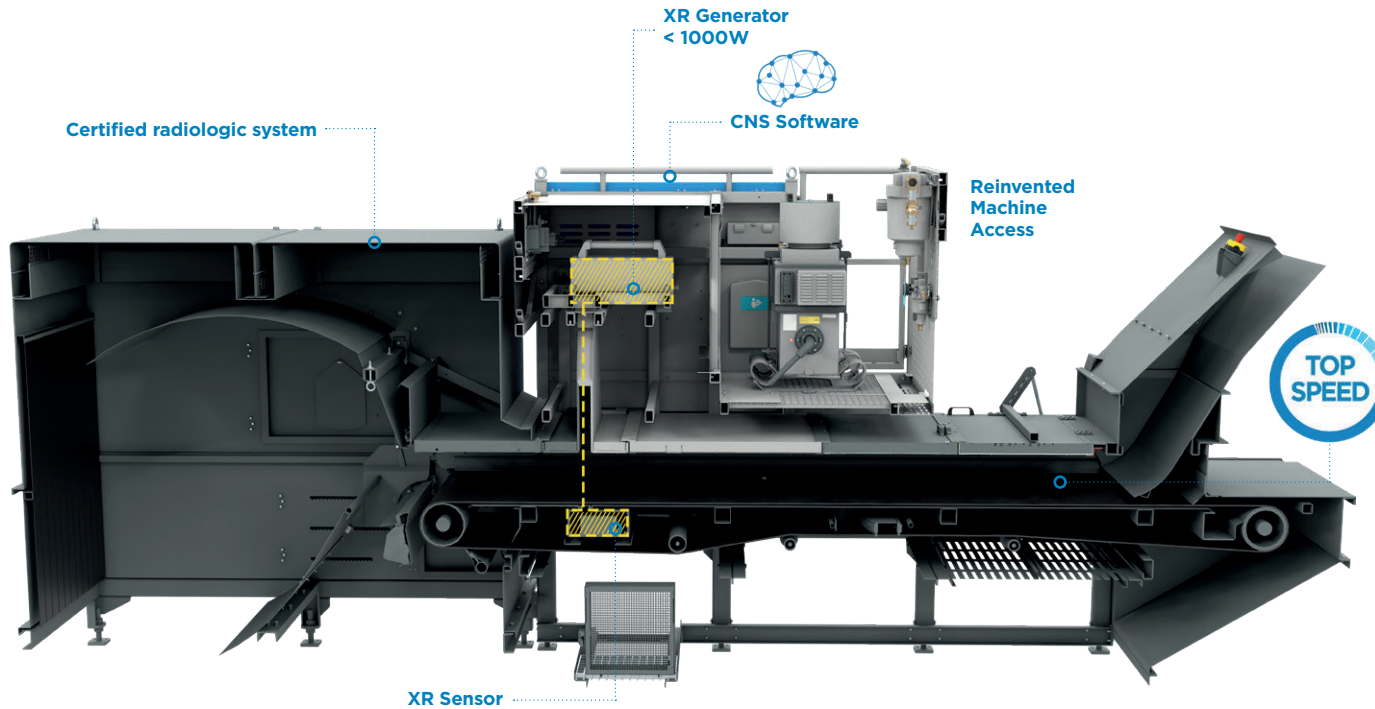

WEEE: Chlorine or brominated plastic removal



Zorba: aluminum cleaning (Twitch)



Aluminum: alloys separation

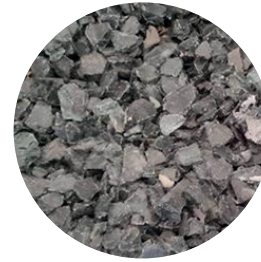

Glass: leaded glass removal

Connected Machine



Connectivity **Smart&Share**



- + **Sorting data and alerting**
- + Protocols : **Modbus, Profinet & OPCUA ready**
- +  **Remote maintenance access**

Features

- + Source power up to 1000W
- + Dual Energy Principle for multidensity sorting
- + Machine learning with shape recognition
- + Continuous and automated calibration
- + Top Speed ready <4,5ms
- + Future Proof