

# MISTRAL+ CONNECT

The most versatile intelligent and connected sorting machine for waste recovery.



## Unmatched performances

### FLOW

DETECTION : a unique design, by Pellenc ST

- + New multi-stream spectrometer
- + Focused light for a more accurate signal
- + Complete coverage of NIR/VIS spectra with a unique spectrometer
- + Optimised Electronic for a better signal/noise ratio

High capacity sorting recognized on the market

- + Turbosorter 3rd generation: 2D Objects stabilisation
- + Top Speed 2nd generation: + 50% capacity with iso performance

## 4.0 Industry & Services

### Sensors to enhance customer relationship

#### Increased availability

- + Conveyor performance analysis
- + Alert to prevent outputbox jams
- + Assistance in the prevention and prediction of conveyor equipment breakage

#### Performance Optimization

- + Stream composition monitoring & alerts
- + Stream distribution monitoring
- + Belt cleanness monitoring

#### Customer Support

- + One year service included
- + Maintenance & Expertise visits
- + Hotline 24/7

## Future Proof

- + Upgradability Guarantee
- + Compatibility of all new sensors (AI, Watermarking, IoT,..) as upgrades



## Full Package : a complete system



- A unique TÜV certified solution
- Designed for simple integration
- Easy and secure machine access

## Low maintenance cost

- Retractable platforms for easy maintenance
- Low replacement rate of wearing parts (electrovalves, lamps)
- Economical Vortex cooling system (no air conditioning)

## 24/7 Customer Service



- A turnkey offer, including wear parts
- Local & personalised support
- Connected machines: Smart&Share



## Configurations

### Widths (mm)

800-1200-1600-2000-2400-2800

### Options



Turbosorter



Profile Detection



Dual Eject



Top Speed



Metal sensor



Multi-channel management

## Materials

PET, PE, PP, paper, wood, domestic waste, organic, RDF...

4 main applications

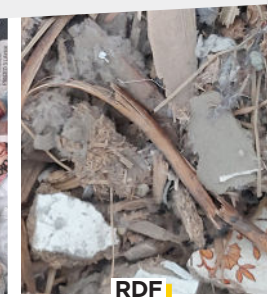

## Valve blocks



Standard : 25mm



High Resolution 12,5mm



High Power : 25mm



Super Power 12,5mm



## Available data

- + **Sorting data available locally**
- + Communication Protocols : **Modbus, Profinet & OPCUA ready**



Remote maintenance access



Connectivity **Smart&Share**

## Easy, quick & safe maintenance

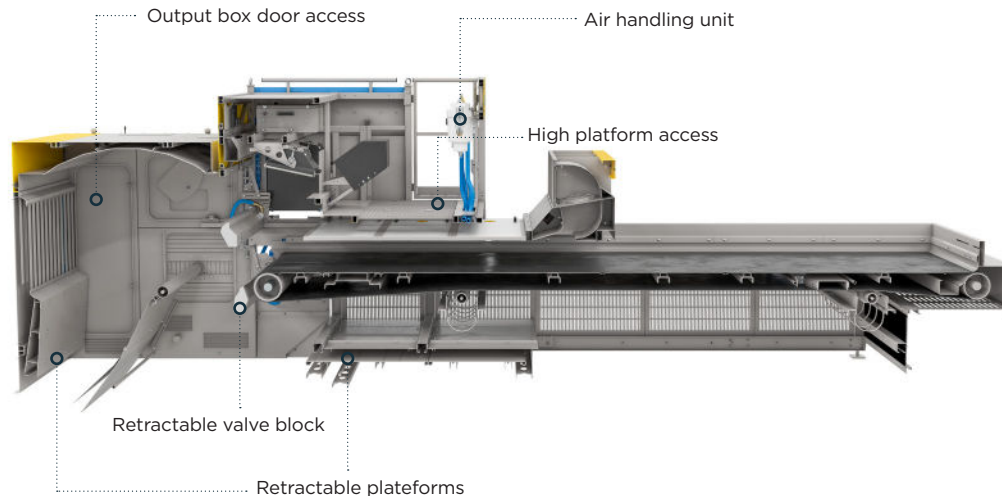

**PROFILE  
DETECTION**

**Black and inert sorting  
Secure & cost-effective technology**



**Better sorting flexibility  
+50% capacity at iso performance**



**High quality & sorting speed  
Robustness: no wearing parts,  
MTBF>20 000h  
Very low energy consumption  
Simple integration**

**FOCUS**

